

PID

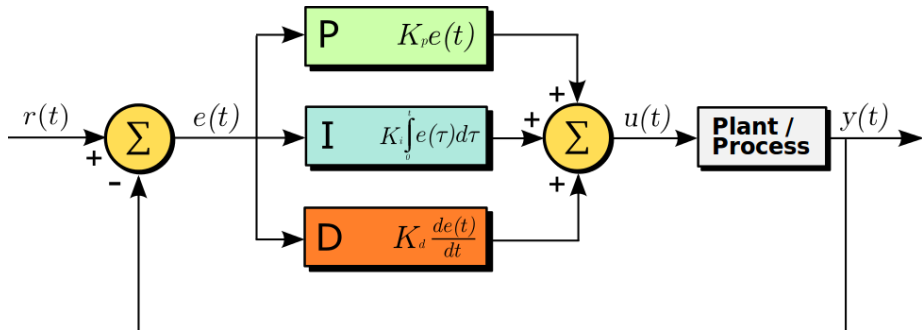

credit:[Wikipedia contributors, 2018]

- $r(t)$: desired setpoint.
- $y(t)$: measured process variable.
- $e(t)$: error value.



Wikipedia contributors (2018). Pid controller — Wikipedia, the free encyclopedia. https://en.wikipedia.org/w/index.php?title=PID_controller&oldid=873472346. [Online; accessed 21-December-2018].