

PID

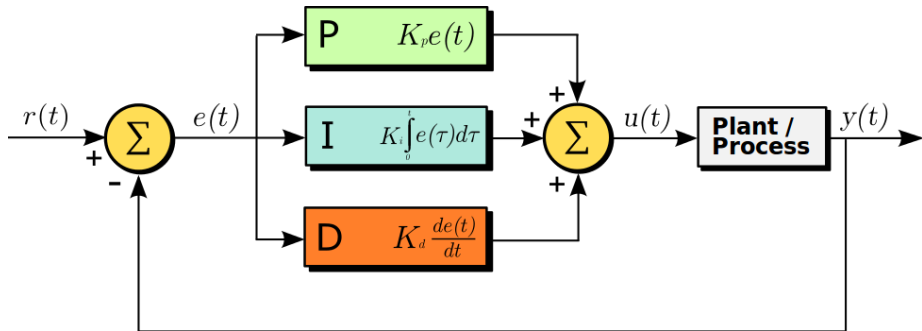

credit:Wikipedia contributors (2018)

► PID@Wiki

- $r(t)$: desired setpoint.
- $y(t)$: measured process variable.
- $e(t)$: error value.
- $u(t)$: control variable.

Wikipedia contributors (2018). PID controller — Wikipedia, The Free Encyclopedia. https://en.wikipedia.org/w/index.php?title=PID_controller&oldid=873472346. [Online; accessed 21-December-2018].