

Poloha přírub vůči ohnisku (1 : 4)

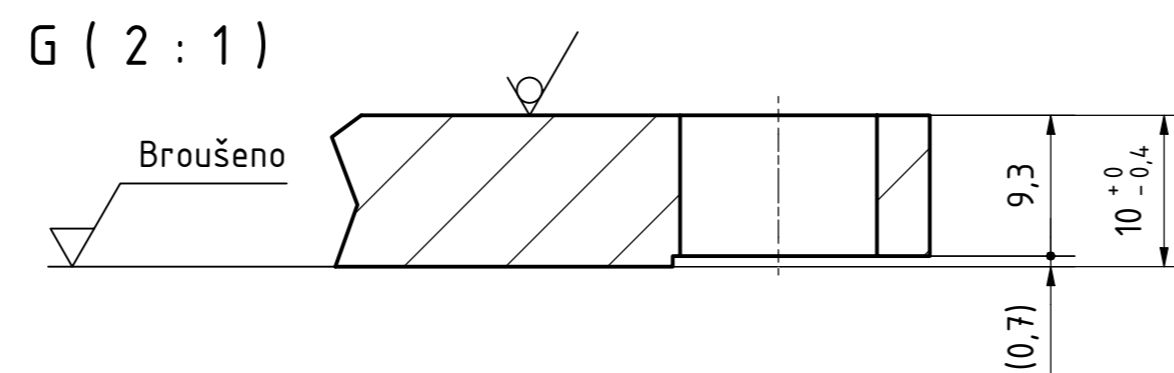

MATERIÁL: Nerezová ocel AISI 304	NAVRHL: Michal Soška	5.5.2021	MĚŘÍTKO: 1 : 2
POLOTOVAR: KRESLIL Michal Soška	21.5.2021		
HMOTNOST: <i>Není k dispozici</i>	TISKL Michal Soška	16.11.2021	KUSŮ: 1
PROMÍTÁNÍ: \oplus (ISO E)	Podpis	Datum	
Název: Příruba 300			
Číslo: CVUT201-101			

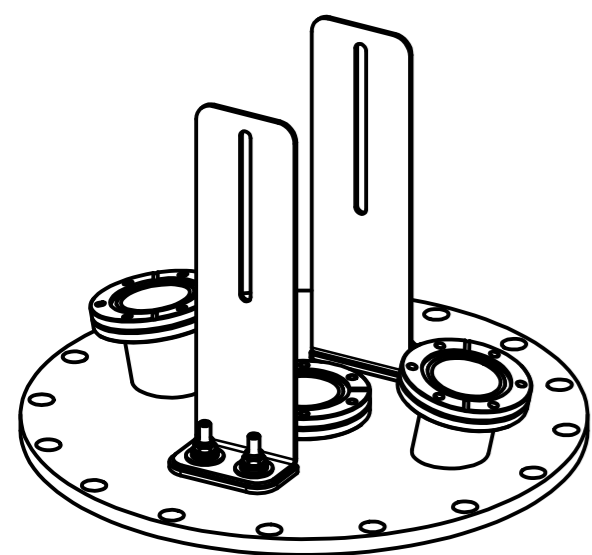
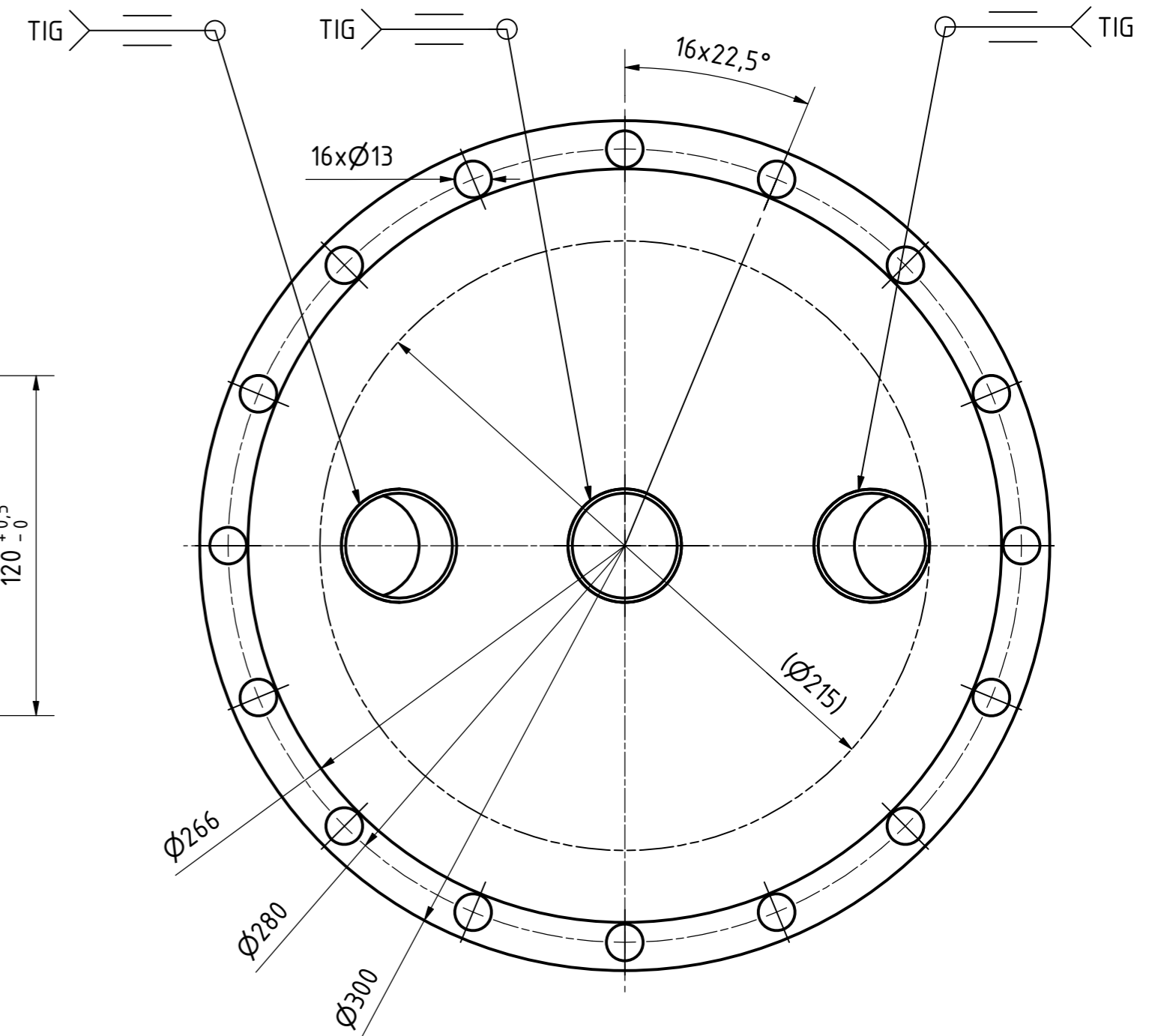
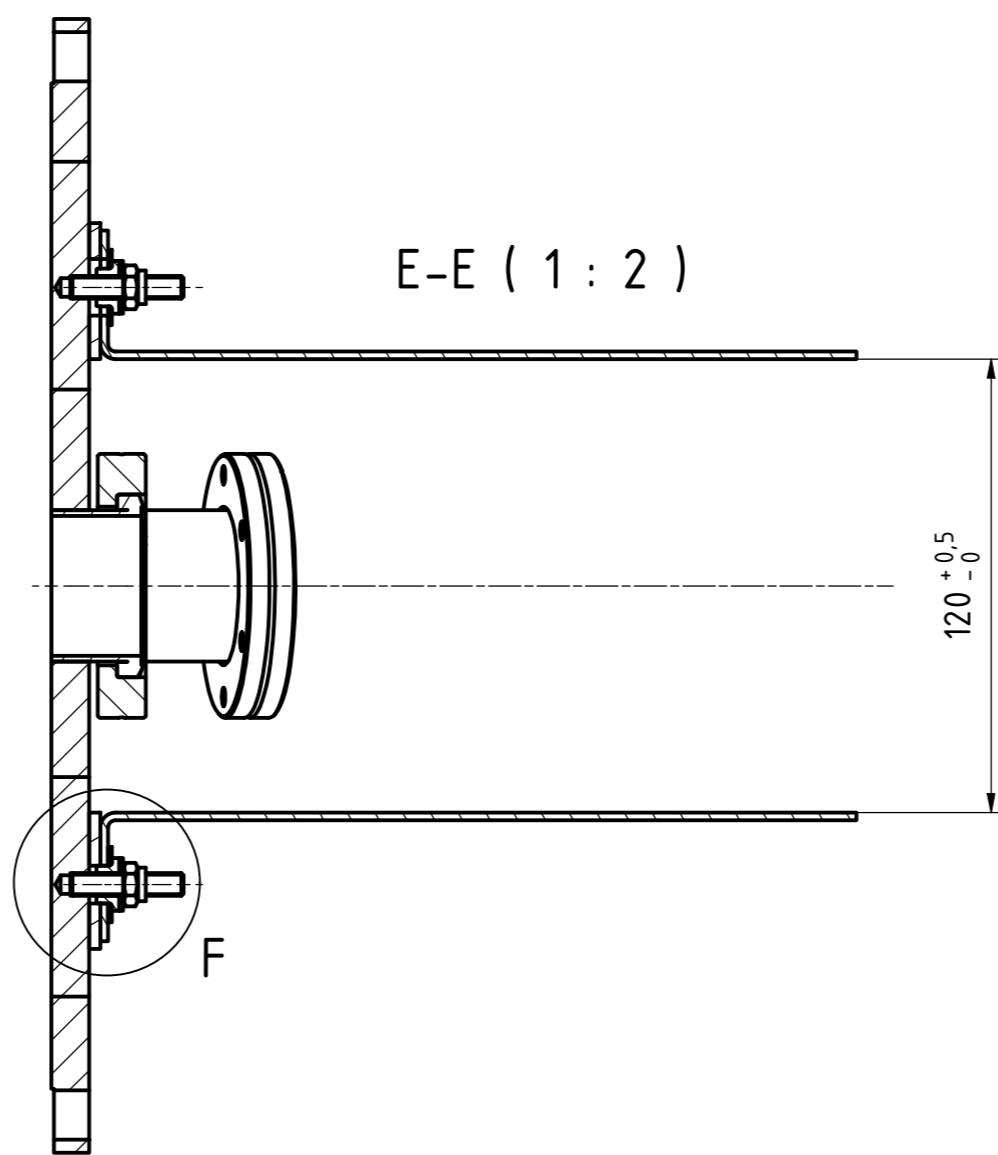
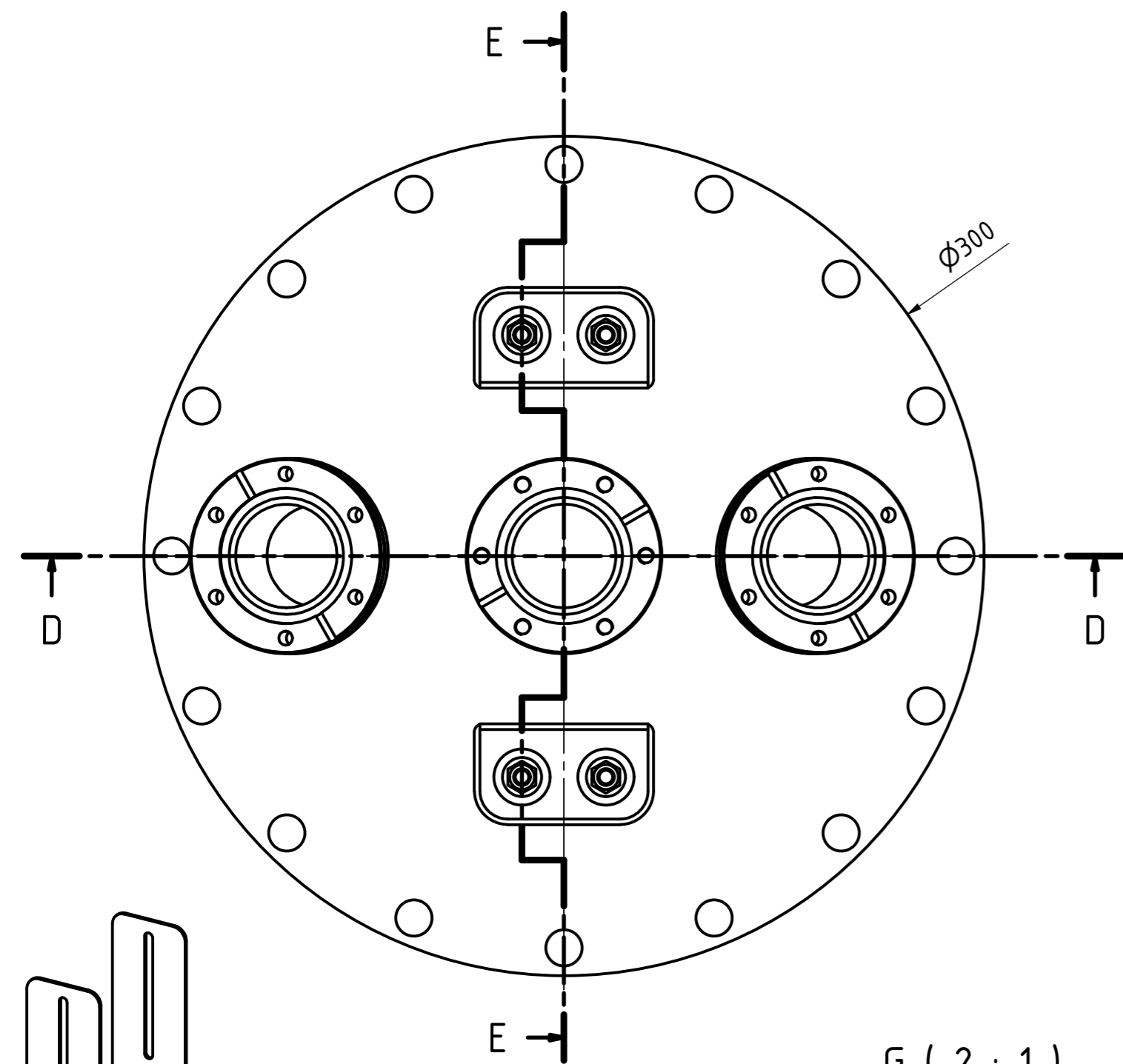
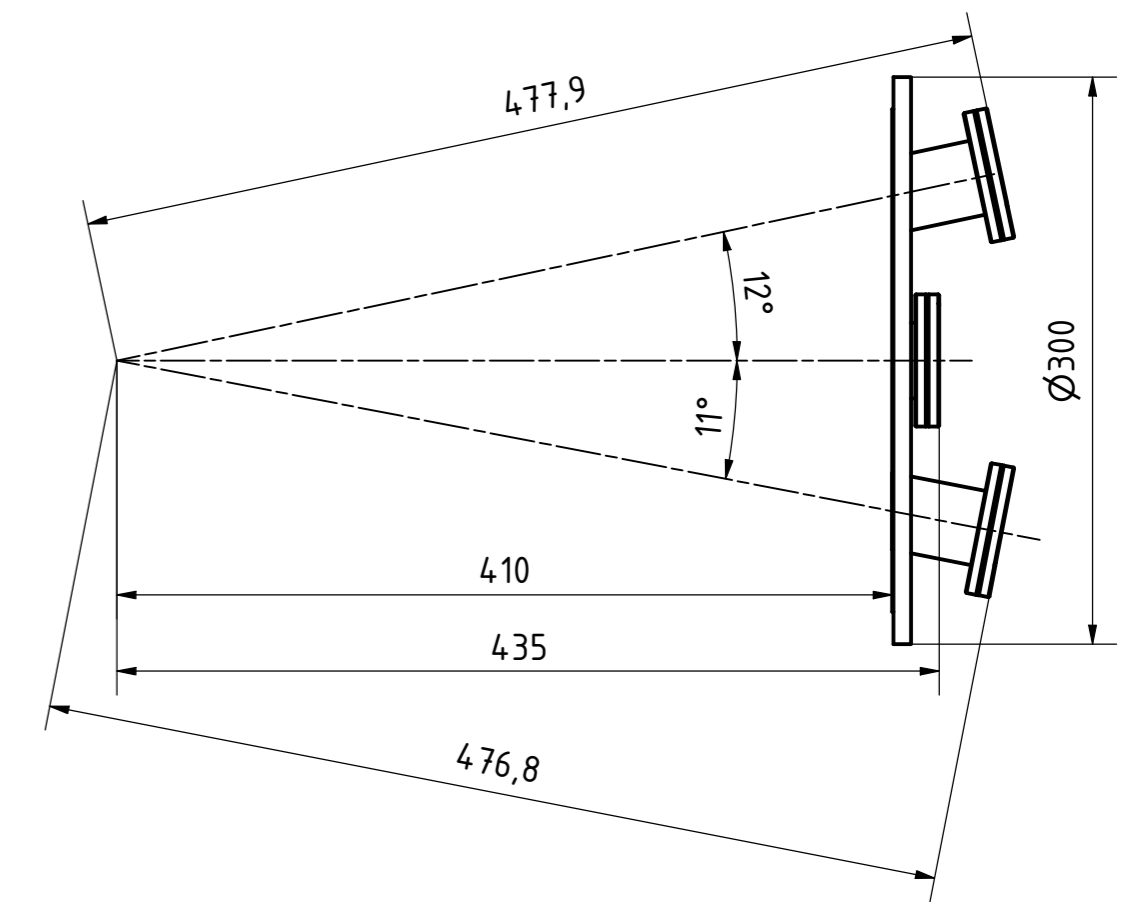