

## Electronic Drive Unit

**TC 400**

## Table of contents

<b>1</b>	<b>About this manual</b> . . . . .	<b>3</b>
1.1	Validity . . . . .	3
1.2	Conventions . . . . .	3
<b>2</b>	<b>Safety</b> . . . . .	<b>4</b>
2.1	Safety precautions . . . . .	4
2.2	Proper use . . . . .	4
2.3	Improper use . . . . .	5
<b>3</b>	<b>Product description</b> . . . . .	<b>5</b>
3.1	Product identification . . . . .	5
3.2	Range of application . . . . .	5
3.3	Function . . . . .	6
3.4	General connection description . . . . .	6
<b>4</b>	<b>Connections diagram</b> . . . . .	<b>7</b>
<b>5</b>	<b>Connection "remote"</b> . . . . .	<b>8</b>
5.1	Pin assignment . . . . .	8
5.2	Operation via "remote" connection . . . . .	8
<b>6</b>	<b>Connection "RS485"</b> . . . . .	<b>11</b>
6.1	Connections . . . . .	11
6.2	Connecting Pfeiffer Vacuum display and control units or PC . . . . .	11
6.3	Cross-linking via the connection RS485 . . . . .	12
<b>7</b>	<b>The Pfeiffer Vacuum parameter set</b> . . . . .	<b>12</b>
7.1	General . . . . .	12
7.2	Parameter overview . . . . .	13
7.3	Configuring the connections . . . . .	17
7.4	Operation with the Pfeiffer Vacuum parameter set . . . . .	19
<b>8</b>	<b>Pfeiffer Vacuum Protocol for "RS485"</b> . . . . .	<b>25</b>
8.1	Telegram frame . . . . .	25
8.2	Telegrams . . . . .	25
8.3	Applied data types . . . . .	26
<b>9</b>	<b>Malfunctions</b> . . . . .	<b>26</b>
9.1	General . . . . .	26
9.2	Operating mode display via LED . . . . .	27
9.3	Error codes . . . . .	27
<b>10</b>	<b>Accessories</b> . . . . .	<b>28</b>
	<b>Declaration of conformity</b> . . . . .	<b>29</b>

# 1 About this manual

## 1.1 Validity

This operating manual is for customers of Pfeiffer Vacuum. It describes the functioning of the designated product and provides the most important information for safe use of the unit. The description follows applicable EU guidelines. All information provided in this operating manual refer to the current state of the product's development. The documentation remains valid as long as the customer does not make any changes to the product.

Up-to-date operating instructions can also be downloaded from [www.pfeiffer-vacuum.net](http://www.pfeiffer-vacuum.net).

## 1.2 Conventions

### Safety instructions

The safety instructions in Pfeiffer Vacuum operating manuals are the result of risk evaluations and hazard analyses and are oriented on international certification standards as specified by UL, CSA, ANSI Z-535, SEMI S1, ISO 3864 and DIN 4844. In this document, the following hazard levels and information are considered:

CAUTION
<p><b>Possible danger</b> Injuries or property damages can occur.</p>
NOTE
<p><b>Command or note</b> Command to perform an action or information about properties, the disregarding of which may result in damage to the product.</p>

### Pictograph definitions



Warning of a displayed source of danger in connection with operation of the unit or equipment.



Command to perform an action or task associated with a source of danger, the disregarding of which may result in serious accidents.

### Instructions in the text

→ Work instruction: here you have to do something.

### Abbreviations used

**DCU:** Display and operating unit  
**HPU:** Handheld programming unit  
**TC:** Electronic drive unit for turbopump  
**TPS:** Mains pack  
**DI / DO:** Digital input / digital output  
**AI / AO:** Analog input / analog output  
**f:** Rotation speed (derived from frequency in Hz)  
**[P:000]:** Parameter of the electronic drive unit with number

## 2 Safety



### NOTE

#### Duty to inform

Each person involved in the installation or operation of the unit must read and observe the safety-related parts of these operating instructions.

→ The operator is obligated to make operating personnel aware of dangers originating from the unit or the entire system.

### 2.1 Safety precautions



### WARNING

#### Ensure safe electrical installation

Safe operation after installation is the responsibility of the operator.

- Do not independently modify or change the pump and electrical equipment.
- Make sure that the system is integrated in an emergency off safety circuit.
- Consult Pfeiffer Vacuum for special requirements.



### WARNING

#### Danger of electric shock

In case of defect, the parts connected to the power supply are under voltage.

→ Always keep the mains connection freely accessible so you can disconnect it at any time.

- **Power supply:** The turbopump power supply must apply to the requirements of double insulation between mains input voltage and operating voltage according to the regulations of IEC 61010 and IEC 60950. Therefore Pfeiffer Vacuum recommends to use exclusively original-power packs and -accessories. Only in this case Pfeiffer Vacuum is able to guarantee the compliance of the European and North American guidelines.
- Observe all safety and accident prevention regulations.
- A safe connection to the protective earthing conductor (PE) is recommended (protection class III).
- Regularly check the proper observance of all safety measures.
- Before carrying out any work disconnect the unit and all associated installations safely from the mains.
- Do not loosen any plug connection during operations.
- The unit has been accredited with protection class IP 54. When installing into ambient conditions, which afford other protection classes, the necessary measures must be taken.
- Keep leads and cables well away from hot surfaces (> 70 °C).
- Only separate the pump and the electronic drive unit from each other after disconnecting the supply voltage and the complete standstill of the pump.

### 2.2 Proper use



### NOTE

#### CE conformity

The manufacturer's declaration becomes invalid if the operator modifies the original product or installs additional components!

→ Following installation into a plant and before commissioning, the operator must check the entire system for compliance with the valid EU directives and reassess it accordingly.

- The electronic drive unit TC 400 operates designated Pfeiffer Vacuum turbo-pumps and their accessories.

## 2.3 Improper use

Improper use will cause all claims for liability and guarantees to be forfeited. Improper use is deemed to be all use for purposes deviating from those mentioned above, especially:

- The use of accessories, which are not named in this manual.
- The operation of the devices in potentially radioactive areas.



### NOTE

#### Warranty seal

The product is sealed at the factory. Damaging or removal of the seal leads to the loss of liability and warranty entitlements.

→ Do not open the product within its warranty period!

→ For process-related shorter maintenance intervals please contact the Pfeiffer Vacuum Service.

## 3 Product description

### 3.1 Product identification

#### Product features

The electronic drive unit TC 400 is an integrated component of the turbopump. Its purpose is to drive, monitor and control the entire pump.

Characteristics	TC 400	
Connection voltage TC	24 V DC $\pm$ 5 %	48 V DC $\pm$ 5 %
Connection panel	Standard (RS485)	Standard (RS485)
Turbopump HiPace	300	300, 400, 700

To correctly identify the product when communicating with Pfeiffer Vacuum, always have the information from the rating plate available.

### 3.2 Range of application

Pfeiffer Vacuum electronic drive units TC 400 must be installed and operated in the following ambient conditions.

Installation location	weather protected (indoors)
Protection category	IP 54
Protection class	III
Temperature	+5 °C to +40 °C (up to +35 °C with air cooling)
Relative humidity	max. 80 %, at T $\leq$ 31 °C, up to max. 50% at T $\leq$ 40 °C
Atmospheric pressure:	77 kPa - 106 kPa
Installation altitude	2000 m max.
Degree of pollution	2
Overvoltage category	II

### 3.3 Function

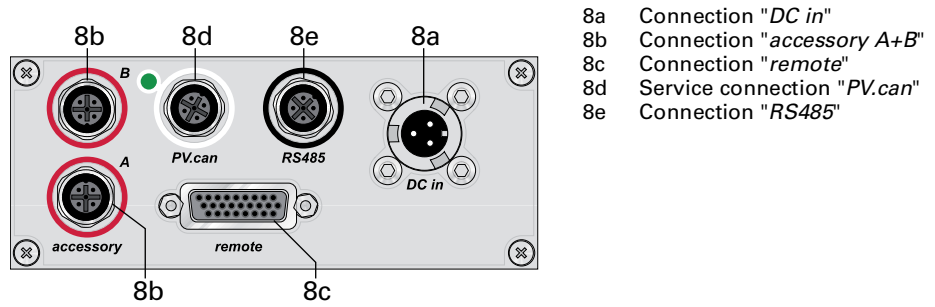







Fig. 1: Standard panel of the TC 400

### 3.4 General connection description

	<b>DC in<sup>1</sup></b> Casing plug with bayonet locking for the voltage supply between Pfeiffer Vacuum mains packs and the electronic drive unit TC.
	<b>accessory</b> M12 socket with screw coupling for the connection of Pfeiffer Vacuum accessories. The use of a Y-connector enables double assignment of one connection.
	<b>PV.can</b> M12 casing socket with screw coupling and LED. The connection "PV.can" serves to service purposes exclusively.
	<b>remote</b> High Density D-sub 26 pole female socket for the connection of a remote control.
	<b>RS485</b> M12 socket with screw coupling for the connection of a Pfeiffer Vacuum control unit or a PC. The use of a Y-connector enables the series connection in a bus system.
	Casing socket on the rear side of the electronic drive unit for the connection to the turbopump.

1. "DC in" and "accessory" are already described in the operating instructions of the turbopump.

# 4 Connections diagram

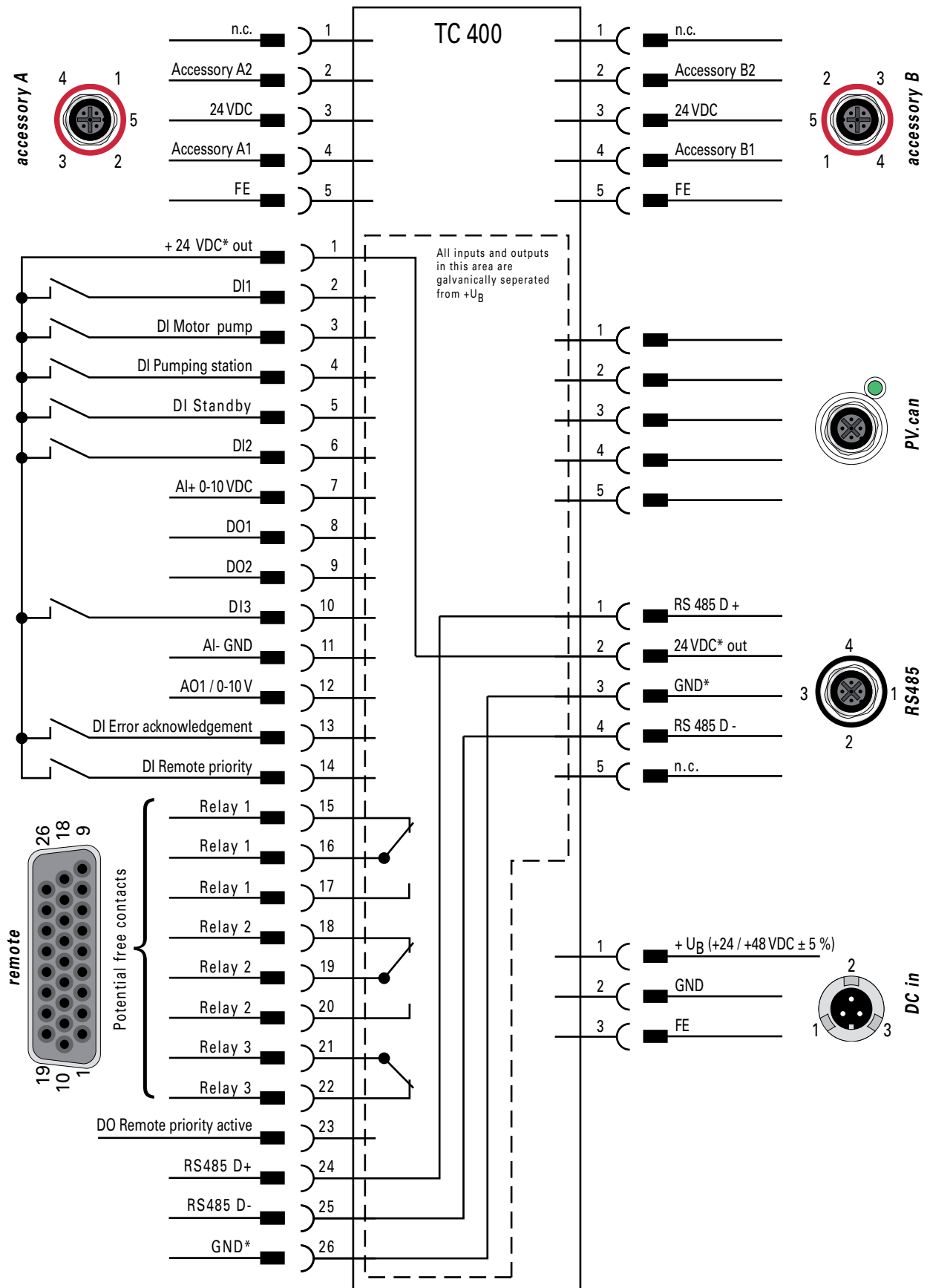
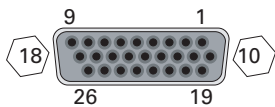

Fig. 2: Connections diagram and assignment of the TC 400

## 5 Connection "remote"



Remote control options are provided via the 26-pole D-Sub connector with the designation "remote" on the electronic drive unit.

- Remove the remote plug from the TC 400 and connect a remote control unit. Pin assignment of the connector according to table.
- Shielded connectors and cables must be used.

### 5.1 Pin assignment

Pin	Function	Designation factory settings
1	+24 VDC output (V+)	Reference voltage for all digital in- and outputs
2	DI1	Enable venting; open: no; V+: yes
3	DI Motor pump	Drive motor; open: off; V+: on
4	DI Pumping station	Open: off; V+: on and error acknowledgement
5	DI Standby	Standby rotation speed; open: off; V+: on
6	DI2	Heating; open: off; V+: on
7	AI+ Rotation speed setting mode	Set value in rotation speed setting mode; 2-10 VDC = 20-100% of the nominal rotation speed
8	DO1	Rotation speed switch point attained; GND:no; V+: yes ( $I_{max} = 50 \text{ mA}/24 \text{ V}$ )
9	DO2	GND: error; V+: no error ( $I_{max} = 50 \text{ mA}/24 \text{ V}$ )
10	DI3	Sealing gas; open: off; V+: on
11	AI- Rotation speed setting mode GND	Set value in rotation speed setting mode; GND
12	AO1	Actual rotation speed; 0-10 VDC is equivalent to 0-100%; $R_L > 10 \text{ k}\Omega$
13	DI Error acknowledgement	Error acknowledgement: V+ pulse (min 500 ms)
14	DI Remote priority	Control via interface "remote"; open: off V+: set and priority over other digital inputs
15	Relais 1	Connection to Pin 16 if relay 1 is inactive
16	Relais 1	Rotation speed switchpoint attained; relay contact 1 ( $U_{max} = 50 \text{ VDC}$ ; $I_{max} = 1 \text{ A}$ )
17	Relais 1	Connection to Pin 16 if relay 1 is active
18	Relais 2	Connection to Pin 19 if relay 2 is inactive
19	Relais 2	No error; relay contact 2 ( $U_{max} = 50 \text{ VDC}$ ; $I_{max} = 1 \text{ A}$ )
20	Relais 2	Connection to Pin 19 if relay 2 is active
21	Relais 3	Connection to Pin 22 if relay 3 is inactive
22	Relais 3	Warning; relay contact 3 ( $U_{max} = 50 \text{ VDC}$ ; $I_{max} = 1 \text{ A}$ )
23	DO Remote priority	GND: off; V+: remote priority active
24	RS485 D+	according to specifications and Pfeiffer Vacuum protocol
25	RS485 D-	according to specifications and Pfeiffer Vacuum protocol
26	Ground (GND)	Reference ground for all digital inputs and all outputs

### 5.2 Operation via "remote" connection

#### +24 VDC\* Output / Pin 1

Inputs 2 - 6 and the connections to Pins 10, 13, 14 are activated by connecting them with +24 VDC to Pin 1 (active high). They can also be activated via an external PLC. The functions are deactivated by "PLC high level" and by "PLC low level".

- PLC high level: +13 V to +33 V
- PLC low level: -33 V to +7 V
- Ri: 7 k $\Omega$

#### Inputs

The digital inputs at connection "remote" are used to connect various functions of the electronic drive unit. Functions are assigned to the inputs DI1 - DI2 ex factory. These can be configured via interface RS485 and the Pfeiffer Vacuum parameter set.

**DI1 (Enable venting) / Pin 2**

V+ : Venting is enabled (venting according to venting mode)  
 open: Venting locked (no venting is performed)

**DI Motor pump / Pin 3**

After Pin 4 (pumping station) is activated and the electronic drive unit successfully completes the self-test (duration approx. 8 seconds), the turbopump is placed into operation. During operation, the turbopump can be switched off and on again, while the pumping station remains switched on. The turbopump is not vented thereby.

V+ : Turbopump motor on  
 open: Turbopump motor off

**DI Pumping station / Pin 4**

Connected pumping station components (e.g. backing pump, venting valve, air cooling unit) are triggered and, with Pin 3 (motor) simultaneously activated, the turbopump is placed in operation. Any ongoing error messages are reset when their cause has been eliminated.

V+ : Malfunction acknowledgement and pumping station on  
 open: Pumping station off

**DI Standby / Pin 5**

In standby mode, the turbopump operates at a specified rotor speed < nominal rotation speed. Factory setting and recommended operation are 66.7 % of the nominal rotation speed.

V+ : Standby activated  
 open: Standby off, operation at nominal rotation speed

**DI2 (Heating) / Pin 6**

V+ : Heating on  
 open: Heating off

**DI3 (Sealing gas) / Pin 10**

V+ : Sealing gas valve open  
 open: Sealing gas valve closed

**DI Error acknowledgement / Pin 13**

V+ : Reset ongoing error messages when cause has been eliminated with a pulse of min. 500 ms duration.  
 open: Inactive

**DI Remote priority / Pin 14**

V+ : The connection "remote" has operation priority over all other digital inputs.  
 open: Remote priority inactive

**AI Rotation speed setting mode / Pin 7 and Pin 11**

The analog input at the TC 400 defines the set rotation speed of the turbopump. An input signal of 2 - 10 V between AI+ (Pin 7) and AI- (Pin 11) corresponds to a rotation speed within the range of 20 - 100% of the nominal rotation speed. If the input is open or signals fall below 2 V, the pump is accelerated up to nominal rotation speed.

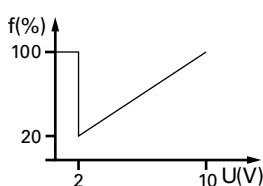

## Outputs

The digital outputs at the connection "*remote*" can be loaded with a maximum of 24 V / 50 mA per output. Outputs DO1 - DO2 are assigned functions in the factory. These can be configured via interface RS485 and the Pfeiffer Vacuum parameter set.

### DO1 (Rotation speed switch point attained) / Pin 8

Active high after the rotation speed switch point is attained. Rotation speed switch point 1 is factory-set to 80% of the nominal rotation speed. It can, for example, be used for a "pump operational" message.

### DO2 (No errors) / Pin 9

When the supply voltage for the TC has been established, digital output DO2 permanently outputs 24 VDC which means "no errors". Active low in case of error (collective error message).

### DO Remote priority active / Pin 23

Active high: The connection "*remote*" takes priority over any other control panels connected to the TC (e.g. RS485). With active low, the connection "*remote*" is ignored.

### AO1 Analog output 0-10 V DC / Pin 12

A rotation-speed-proportional voltage (0-10 VDC equals 0 - 100 % x  $f_{\text{Nominal}}$ ) can be picked up via the analog output (load  $R \geq 10 \text{ k}\Omega$ ). Additional functions (optionally current/power) can be assigned to the analog output via DCU, HPU or PC.

## Relay contacts

### Relay 1 / Pin 15, Pin 16 and Pin 17

The contact between Pin 16 and Pin 15 is closed when the rotation speed switch point is underrun; relay 1 is inactive. The contact between Pin 16 and Pin 17 is closed when the rotation speed switch point is attained; relay 1 is active.

### Relay 2 / Pin 18, Pin 19 and Pin 20

The contact between Pin 19 and Pin 18 is closed when operation is malfunction free; relay 2 is inactive. The contact between Pin 19 and Pin 20 is closed when a malfunction is present; relay 2 is active.

### Relay 3 / Pin 21 and Pin 22

The contact between Pin 21 and Pin 22 is closed when no warning messages are active; relay 3 is inactive. The contact between Pin 21 and Pin 22 is open when a warning message is present; relay 3 is active.

## RS485

One Pfeiffer Vacuum display and control panel (DCU **or** HPU) **or** an external PC can be connected respectively to the electronic drive unit via Pin 24 and Pin 25 of the connection "*remote*" on the electronic drive unit.

→ Establish the connections according to the specification of the interface RS485.

## 6 Connection "RS485"

### 6.1 Connections

A Pfeiffer Vacuum display and control panel (DCU or HPU) or an external PC can be connected to the electronic drive unit via the connection designated "RS485". The interface is electrically isolated from the maximum supply voltage of the electronic drive unit. The electrical couplings are optically decoupled internally.

Designation	Value
Serial interface	RS485
Baud rate	9600 Baud
Data file word length	8 bit
Parity	keine (no parity)
Start bits	1
Stop bits	1..2

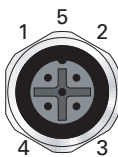

Pin	Assignment
1	RS485: D+
2	+24 V output, loadable with $\leq 210$ mA
3	GND
4	RS485: D-
5	not connected

### 6.2 Connecting Pfeiffer Vacuum display and control units or PC

- ➔ Use the connection cable supplied with the control panel or from the range of accessories.
- ➔ The connection of respectively one external operating unit is possible on the interface RS 485.
- ➔ A USB interface (PC) can be connected via the USB/RS485-converter.

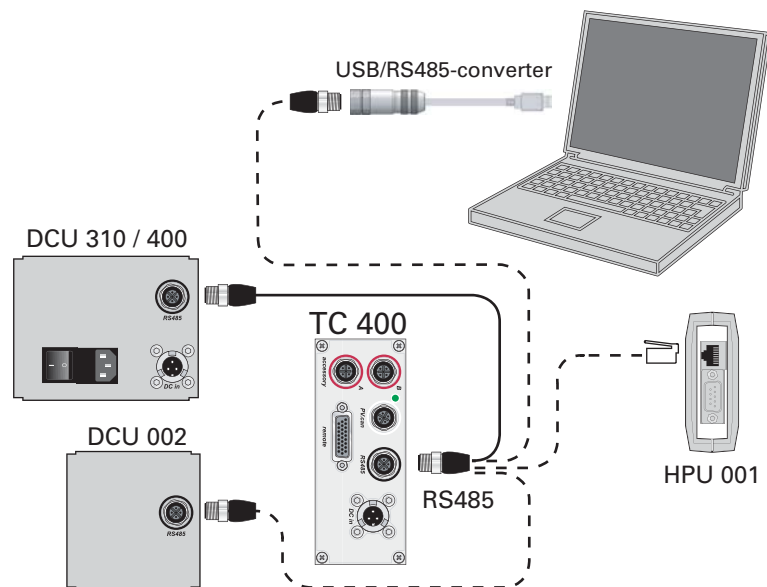
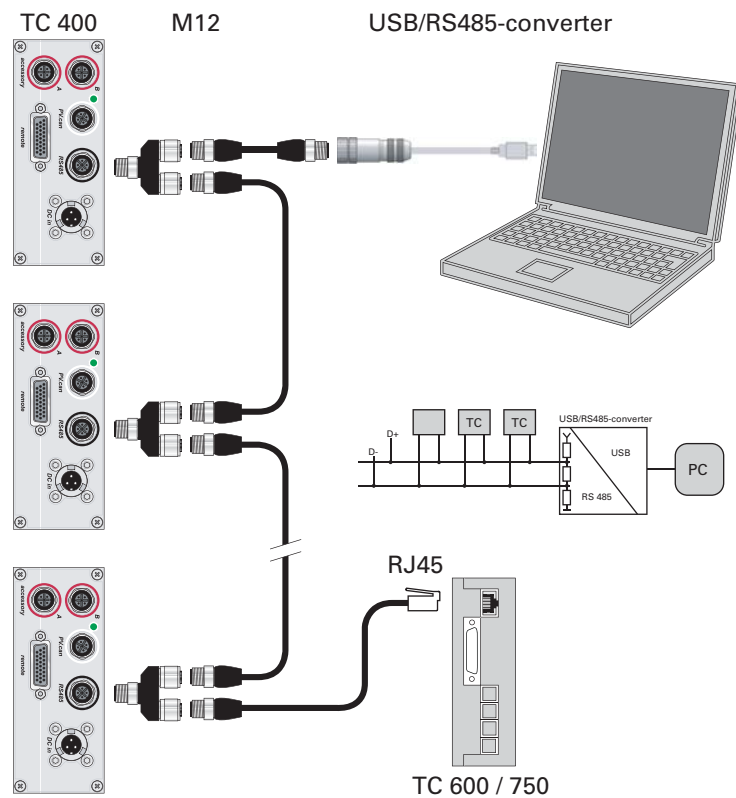

Fig. 3: Optional connection possibilities for interface RS485

## 6.3 Cross-linking via the connection RS485



### CAUTION

#### Danger of electric shock

The insulation measures of the bus system are designed only for use with safety extra-low voltage.

→ Connect only suitable devices to the bus system.

- Establish the connections according to the specification of the interface RS485.
- Connect all units with D+ and D- to the bus.
- The group address of the electronic drive unit is 962.
- All units connected to the bus must have differing RS485 device addresses [P:797].

## 7 The Pfeiffer Vacuum parameter set

### 7.1 General

All function-relevant variables of a turbopump are anchored in the corresponding electronic drive unit in the form of parameters. Each parameter has a three-digit number and a designation. Parameters can be used via Pfeiffer Vacuum display and control panels or via RS485 with the Pfeiffer Vacuum protocol.



**NOTE**

**Additional parameters in the control unit**

For the control of connected external components (e.g. vacuum measurement devices) there are additional parameters fixed in the respective Pfeiffer Vacuum display and control unit.

→ Please consider the respective operating instructions.

**Conventions**

Parameters are displayed in square brackets as a three-digit number in bold font. The designation may also be stated if necessary.

Example: **[P:002] Standby**

**7.2 Parameter overview**

**Annotation**

<b>#</b>	Three figure number of the parameter
<b>Display</b>	Notification of the parameter in a Pfeiffer Vacuum display and control unit
<b>Designation</b>	Short description of the parameter
<b>Functions</b>	Functional description of the parameter
<b>Data type</b>	Type of formatting of the parameter for the use within the Pfeiffer Vacuum protocol
<b>Access method</b>	R: read access; W: write access
<b>Unit</b>	Physical unit of the described characteristic
<b>min / max</b>	permissible limits for value input
<b>default</b>	factory settings (partially specific of the pump type)
	Parameter can be stored non volatile in the electronic drive unit and may be reused after resetting of the mains supply.

**Control commands**

#	Display	Designation	Functions	Data type	Access method	Unit	min	max	default	
001	Heating	Heating	0 = off 1 = on	0	RW		0	1	0	x
002	Standby	Standby	0 = off 1 = on	0	RW		0	1	0	x
004	RUTimeCtrl	Run-up time control	0 = off 1 = on	0	RW		0	1	1	x
009	ErrorAckn	Error acknowledgement	1 = Error acknowledgement	0	W		1	1		x
010	PumpgStatn	Pumping station	0 = off 1 = on and error acknowledgement	0	RW		0	1	0	x
012	EnableVent	Enable venting	0 = no 1 = yes	0	RW		0	1	0	x
017	CfgSpdSwPt	Configuration rotation speed switch point	0 = Rotation speed switch point 1 1 = Rotation speed switch point 1&2	7	RW		0	1	0	x

#	Display	Designation	Functions	Data type	Access method	Unit	min	max	default	
019	Cfg DO2	Configuration output DO2	0 = Rot. speed switch point attained 1 = No error 2 = Error 3 = Warning 4 = Error and/or warning 5 = Set speed attained 6 = Pump on 7 = Pump accelerates 8 = Pumpe decelerates 9 = always 0 10 = always 1 11 = Remote priority active 12 = Heating 13 = Backing pump 14 = Sealing gas 15 = Pumping station	7	RW		0	15	1	x
023	MotorPump	Motor pump	0 = off 1 = on	0	RW		0	1	0	x
024	Cfg DO1	Configuration output DO1	0 = Rot. speed switch point attained 1 = No error 2 = Error 3 = Warning 4 = Error and/or warning 5 = Set speed attained 6 = Pump on 7 = Pump accelerates 8 = Pumpe decelerates 9 = always 0 10 = always 1 11 = Remote priority active 12 = Heating 13 = Backing pump 14 = Sealing gas 15 = Pumping station	7	RW		0	15	0	x
025	OpMode BKP	Operation mode backing pump	0 = Continuous operating 1 = Intermittend mode 2 = Delayed switch-on	7	RW		0	2	0	x
026	SpdSetMode	Rotation speed setting mode	0 = off 1 = on	7	RW		0	1	0	x
027	GasMode	Gas mode	0 = Heavy Gase 1 = Light Gase 2 = Helium	7	RW		0	1	0	x
030	VentMode	Venting mode	0 = Delayed venting 1 = No venting 2 = Direct venting	7	RW		0	2	0	x
035	Cfg Acc A1	Configuration accessory connection A1	0 = Fan (continuous operation) 1 = Venting valve, normally closed 2 = Heating 3 = Backing pump 4 = Fan (temperature controlled) 5 = Sealing gas 6 = always 0 7 = always 1 8 = Venting valve, normally open	7	RW		0	7	0	x
036	Cfg Acc B1	Configuration accessory connection B1	0 = Fan (continuous operation) 1 = Venting valve, normally closed 2 = Heating 3 = Backing pump 4 = Fan (temperature controlled) 5 = Sealing gas 6 = always 0 7 = always 1 8 = Venting valve, normally open	7	RW		0	7	1	x

#	Display	Designation	Functions	Data type	Access method	Unit	min	max	default	
037	Cfg Acc A2	Configuration accessory connection A2	0 = Fan (continuous operation) 1 = Venting valve, normally closed 2 = Heating 3 = Backing pump 4 = Fan (temperature controlled) 5 = Sealing gas 6 = always 0 7 = always 1 8 = Venting valve, normally open	7	RW		0	7	3	x
038	Cfg Acc B2	Configuration accessory connection B2	0 = Fan (continuous operation) 1 = Venting valve, normally closed 2 = Heating 3 = Backing pump 4 = Fan (temperature controlled) 5 = Sealing gas 6 = always 0 7 = always 1 8 = Venting valve, normally open	7	RW		0	7	2	x
045	Cfg Rel R1	Configuration Relay 1	0 = Rot. speed switch point attained 1 = No error 2 = Error 3 = Warning 4 = Error and/or warning 5 = Set speed attained 6 = Pump on 7 = Pump accelerates 8 = Pump decelerates 9 = always 0 10 = always 1 11 = Remote priority active 12 = Heating 13 = Backing pump 14 = Sealing gas 15 = Pumping station	7	RW		0	15	0	x
046	Cfg Rel R2	Configuration Relay 2	0 = Rot. speed switch point attained 1 = No error 2 = Error 3 = Warning 4 = Error and/or warning 5 = Set speed attained 6 = Pump on 7 = Pump accelerates 8 = Pump decelerates 9 = always 0 10 = always 1 11 = Remote priority active 12 = Heating 13 = Backing pump 14 = Sealing gas 15 = Pumping station	7	RW		0	15	1	x
047	Cfg Rel R3	Configuration Relay 3	0 = Rot. speed switch point attained 1 = No error 2 = Error 3 = Warning 4 = Error and/or warning 5 = Set speed attained 6 = Pump on 7 = Pump accelerates 8 = Pump decelerates 9 = always 0 10 = always 1 11 = Remote priority active 12 = Heating 13 = Backing pump 14 = Sealing gas 15 = Pumping station	7	RW		0	15	3	x
050	SealingGas	Sealing gas	0 = off 1 = on	0	RW		0	1	0	x

#	Display	Designation	Functions	Data type	Access method	Unit	min	max	default	
055	Cfg AO1	Configuration output AO1	0 = Actual rotation speed 1 = Power 2 = Current 3 = always 0 V 4 = always 10 V 5 = follows AI1	7	RW		0	5	0	x
057	Cfg AI1	Configuration input AI1	0 = Disconnected 1 = Set value rot. speed setting mode	7	RW		0	1	0	x
060	CtrlVialnt	Control via interface	1 = Remote 2 = RS485 4 = PV,can 8 = Field bus 16 = E74	7	RW		1	255	1	x
061	IntSelLckd	Interface selection locked	0 = no 1 = yes	0	RW		0	1	0	x
062	Cfg DI1	Configuration input DI1	0 = Deactivated 1 = Enable venting 2 = Heating 3 = Sealing gas 4 = Run-up time control 5 = Rotation speed setting mode Setting ≠[P:063/064]	7	RW		0	5	1	x
063	Cfg DI2	Configuration input DI2	0 = Deactivated 1 = Enable venting 2 = Heating 3 = Sealing gas 4 = Run-up time control 5 = Rotation speed setting mode Setting ≠[P:062/064]	7	RW		0	5	2	x
064	Cfg DI3	Konfiguration input DI3	0 = Deactivated 1 = Enable venting 2 = Heating 3 = Sealing gas 4 = Run-up time control 5 = Rotation speed setting mode Setting ≠[P:062/063]	7	RW		0	5	3	x

### Status requests

#	Display	Designation	Functions	Data type	Access method	Unit	min	max	default	
300	RemotePrio	Remote priority	0 = no 1 = yes	0	R		0	1		
302	SpdSwPtAtt	Rotation speed switch point attained	0 = no 1 = yes	0	R		0	1		
303	Error code	Error code		4	R					
304	OvTempElec	Excess temperature electronic drive unit	0 = no 1 = yes	0	R		0	1		
305	OvTempPump	Excess temperature pump	0 = no 1 = yes	0	R		0	1		
306	SetSpdAtt	Set rotation speed attained	0 = no 1 = yes	0	R		0	1		
307	PumpAccel	Pump accelerates	0 = no 1 = yes	0	R		0	1		
308	SetRotSpd	Set rotation speed (Hz)		1	R	Hz	0	999999		
309	ActualSpd	Actual rotation speed (Hz)		1	R	Hz	0	999999		
310	DrvCurrent	Drive current		2	R	A	0	9999.99		
311	OpHrsPump	Operating hours pump		1	R	h	0	65535		x
312	Fw version	Firmware version electronic drive unit		4	R					
313	DrvVoltage	Drive voltage		2	R	V	0	9999.99		
314	OpHrsElec	Operating hours electronic drive unit		1	R	h	0	65535		x
315	Nominal Spd	Nominal rotation speed (Hz)		1	R	Hz	0	999999		
316	DrvPower	Drive power		1	R	W	0	999999		
319	PumpCylces	Pump cycles		1	R		0	65535		x
324	TempPwrStg	Temperature power stage		1	R	°C	0	999999		

#	Display	Designation	Functions	Data type	Access method	Unit	min	max	default	
326	TempElec	Temperature electronic		1	R	°C	0	999999		
330	TempPmpBot	Temperature pump bottom part		1	R	°C	0	999999		
336	AccelDecel	Acceleration / Deceleration		1	R	rpm/s	0	999999		
342	TempBearng	Temperature bearing		1	R	°C	0	999999		
346	TempMotor	Temperature motor		1	R	°C	0	999999		
349	ElecName	Name of electronic drive unit		4	R					
354	HW Version	Hardware version electronic drive unit		4	R					
360	ErrHist1	Error code history, pos. 1		4	R					x
361	ErrHist2	Error code history, pos. 2		4	R					x
362	ErrHist3	Error code history, pos. 3		4	R					x
363	ErrHist4	Error code history, pos. 4		4	R					x
364	ErrHist5	Error code history, pos. 5		4	R					x
365	ErrHist6	Error code history, pos. 6		4	R					x
366	ErrHist7	Error code history, pos. 7		4	R					x
367	ErrHist8	Error code history, pos. 8		4	R					x
368	ErrHist9	Error code history, pos. 9		4	R					x
369	ErrHist10	Error code history, pos. 10		4	R					x
384	TempRotor	Temperature rotor		1	R	°C	0	999999		
397	SetRotSpd	Set rotation speed (rpm)		1	R	rpm	0	999999		
398	ActualSpd	Actual rotation speed (rpm)		1	R	rpm	0	999999		
399	NominalSpd	Nominal rotation speed (rpm)		1	R	rpm	0	999999		

### Set value settings

#	Display	Designation	Functions	Data type	Access method	Unit	min	max	default	
700	RUTimeSVal	Set value run-up time		1	RW	min	1	120	8	x
701	SpdSwPt1	Rotation speed switch point 1		1	RW	%	50	97	80	x
707	SpdSVal	Set value in rot. speed setting mode		2	RW	%	20	100	50	x
708	PwrSVal	Set value power consumption		7	RW	%	10	100	100 <sup>1</sup>	x
710	Swoff BKP	Switching off threshold backing pump in intermitten mode		1	RW	W	0	1000	0	x
711	SwOn BKP	Switching on threshold backing pump in intermitten mode		1	RW	W	0	1000	0	x
717	StdbySVal	Set value rotation speed at standby		2	RW	%	20	100	66.7	x
719	SpdSwPt2	Rotation speed switch point 2		1	RW	%	5	97	20	x
720	VentSpd	Venting rot. speed at delayed venting		7	RW	%	40	98	50	x
721	VentTime	Venting time at delayed venting		1	RW	s	6	3600	3600	x
777	NomSpdConf	Nominal rotation speed confirmation		1	RW	Hz	0	1500		x
797	RS485Adr	RS485 device address		1	RW		1	255	1	x

1. depending on the pump type

## 7.3 Configuring the connections

The electronic drive unit is pre-configured in the factory. Thereby the turbopump is immediately operational with the necessary functions. The connections of the electronic drive unit can be configured to suit individual requirements using the parameter set.

**Accessory connection** → Configuration via parameters [P:035], [P:036], [P:037] or [P:038].

Option	Description
0 = Fan (continuous operation)	Control via parameter Pumping station
1 = Venting valve, normally closed	Control via parameter Enable venting, when using a venting valve which is normally closed.
2 = Heating	Control via parameters Heating and Rotation speed switchpoint attained
3 = Backing pump	Control via parameters Pumping station and operation mode backing pump
4 = Fan (temperature controlled)	Control via parameter Pumping station and temperature thresholds

Option	Description
5 = Sealing gas	Control via parameters Pumping station and Sealing gas
6 = always 0	GND for the control of an external device
7 = always 1	+24 VDC for the control of an external device
8 = Venting valve, normally open	Control via parameter Enable venting, when using a venting valve which is normally open.

### Digital inputs on "remote"

→ Configuration via parameters [P:062], [P:063] or [P:064].

Option	Description
0 = deaktiviert	Connection deactivated
1 = Enable venting	Control is equal to parameter [P:012]
2 = Heating	Control is equal to parameter [P:001]
3 = Sealing gas	Control is equal to parameter [P:050]
4 = Run-up time control	Control is equal to parameter [P:004]
5 = Rotation speed setting mode	Control is equal to parameter [P:026]

### Digital outputs and relays on "remote"

→ Configuration via parameters [P:019] and [P:024], respectively [P:045], [P:046] and [P:047].

Option	Description
0 = Rotation speed switchpoint attained	Signal, if switchpoint attained
1 = No error	Signal, if failure-free operation
2 = Error	Signal, if error message is active
3 = Warning	Signal, if warning message is active
4 = Error and / or warning	Signal, if error and / or warning is active
5 = Set rotation speed attained	Signal, if set rotation speed is attained
6 = Pump on	Signal, if Pumping station and Motor is on; No Error
7 = Pump accelerates	Pumping station is on; Actual rotation speed < Set rotation speed
8 = Pumpe decelerates	Pumping station is on; Actual rotation speed > Set rotation speed Pumping station is off; Rotation speed > 3 Hz
9 = always 0	GND for the control of an external device
10 = always 1	+24 VDC for the control of an external device
11 = Remote priority active	Signal, if Remote priority is active
12 = Heating	Control is equal to parameter [P:001]
13 = Backing pump	Control via parameter Pumping station and operation mode backing pump
14 = Sealing gas	Control is equal to parameter [P:050]
15 = Pumping station	Control is equal to parameter [P:010]

### Analog output on "remote"

→ Configuration via parameter [P:055].

Option	Description
0 = Rotation speed	Rotation speed signal; $0 - 10 \text{ VDC} = 0 - 100 \% \times f_{\text{Nominal}}$
1 = Power	Power signal; $0 - 10 \text{ VDC} = 0 - 100 \% \times P_{\text{max}}$
2 = Current	Current signal; $0 - 10 \text{ VDC} = 0 - 100 \% \times I_{\text{max}}$
3 = always 0 V	always GND
4 = always 10 V	output of continuously 10 V DC
5 = follows AI1	follows the analogue input 1

### Analog input on "remote"

→ Configuration via parameter [P:057].

Option	Description
0 = Switched off	Connection is deactivated
1 = Set value in rotation speed setting mode	Rotation speed setting mode via pin 7 (0 - 10 V) and pin 11 (GND)

**Control via interface** → Configuration via parameters [P:060] and [P:061].

Option [P:060]	Description
1 = remote	Operation via connection "remote"
2 = RS485	Operation via connection "RS485"
4 = PV.can	For service purposes only
8 = Field bus	Operation via field bus
16 = E74	Operation via connection "E74"

Option [P:061]	Description
0 = no	Interface selection via [P:060]
1 = yes	Interfaces selection locked

## 7.4 Operation with the Pfeiffer Vacuum parameter set

**Factory settings** The electronic drive unit is pre-programmed in the factory. This guarantees proper, reliable turbopump operation without the need for additional configuration.

**Checking the adjustments**

- Before operating with parameters, check set values and control commands for their suitability for the pumping process.
- Remove the remote plug from electronic drive unit if required.

**Gas type dependent operations** Friction causes the rotor to heat up severely under gas load and high rotation speed. To avoid overheating, the electronic drive unit has implemented power-rotation speed-characteristics, whereby the pump can be operated at every rotation speed with the maximum allowable gas load without danger of damage. The maximum power consumption depends on the gas type. Three characteristics are available in order to completely exhaust the pump's capacity for each gas type.



### CAUTION

#### Danger of the pump being destroyed

Pumping of gases with a higher molecular mass in the wrong gas mode can lead to destruction of the pump.

- Ensure the gas mode is correctly set.
- Contact Pfeiffer Vacuum before using gases with a greater molecular mass (> 80).

- Gas mode "0" for gases with the molecular mass >39, e.g. Ar.
- Gas mode "1" for gases with the molecular mass ≤ 39.
- Gas mode "2" for helium.
- Power characteristics according to the technical data of the turbopump.

→ Check and set-up the gas mode via [P:027].

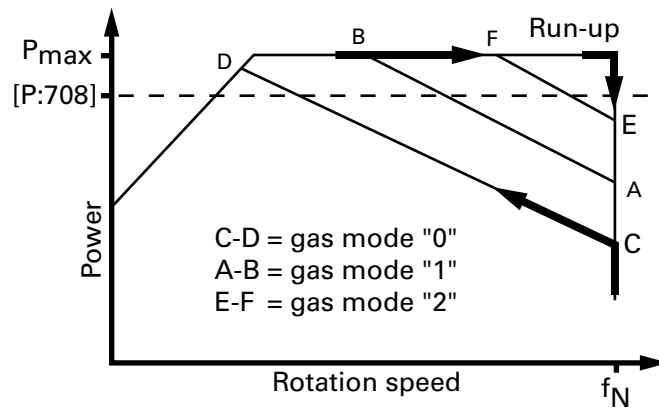

**Fig. 4: Principle of power characteristics lines for gas type dependent operations, e.g. gas mode = 0**

The turbopump runs up with maximum power consumption. When the nominal and/or set rotation speed is reached, the pump automatically switches over to the chosen power characteristic of the selected gas mode. Increasing gas load is initially compensated by a rise in power consumption in order to keep the rotation speed constant. Increasing gas friction, however, causes the turbopump to heat up more severely. When the gastype-dependent maximum power is exceeded, the rotation speed of the turbopump is reduced until an equilibrium between permissible power and gas friction is attained.

→ To avoid rotation speed fluctuations, Pfeiffer Vacuum recommends setting a somewhat lower frequency in rotation speed setting mode.

### Set value power consumption

→ Adjust the parameter **[P:708]** to the desired value in %.

If adjusting the set value power consumption below 100 % the run-up time prolongs. To avoid error messages, the parameter **[P:700] RUTimeSVal** should be adjusted accordingly.

### Run-up time

The run-up of the turbopump is time-monitored ex factory. There are various causes of prolonged run-up times, e.g.:

- Too high gas loads
- Leakage in the system
- The set value run-up time is too low

→ Eliminate any external and application-related causes.

→ Adjust the run-up time via parameter **[P:700]**.

### Adjusting the rotation speed switchpoint

The rotation speed switch point can be used for the message "Pump operational for the process". Overrunning or underrunning the active rotation speed switch point activates or deactivates a signal at the pre-configured output on the electronic drive unit and at the status parameter **[P:302]**.

#### Rotation speed switchpoint 1

→ Adjust the parameter **[P:701]** to the desired value in %.

→ Parameter **[P:017] = 0**

Signal output and status parameter **[P:302]** are based on the set value for rotation speed switch point 1 **[P:701]**.

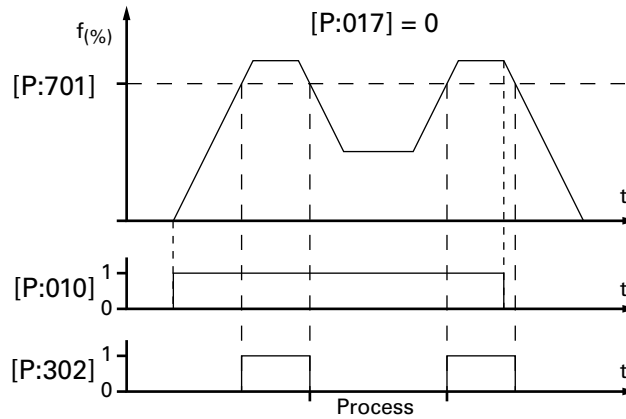

Fig. 5: Example for the configuration rotation speed switch point 1 active

### Rotation speed switchpoint 1 & 2

- Adjust the parameter [P:701] to the desired value in %.
- Adjust the parameter [P:719] to the desired value in %.
- Parameter [P:017] = 1

When the pumping station [P:010] is switched on, the rotation speed switch point 1 is the signal generator. When the pumping station is switched off, signal output and status query are based on the rotation speed switch point 2. The signal output is governed by the hysteresis between the two switch points.

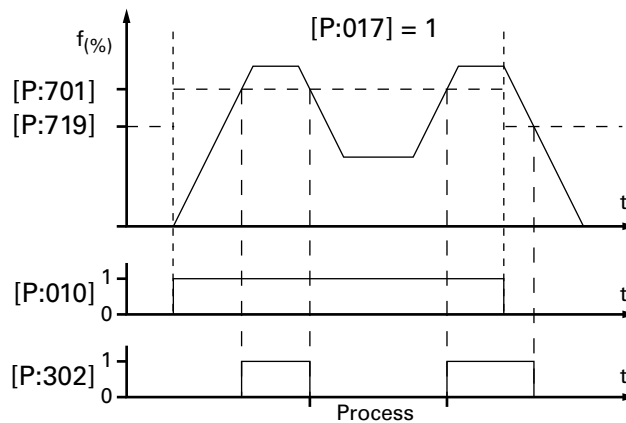

Fig. 6: Example for the configuration rotation speed switch point 1+2 active; [P:701] > [P:719]

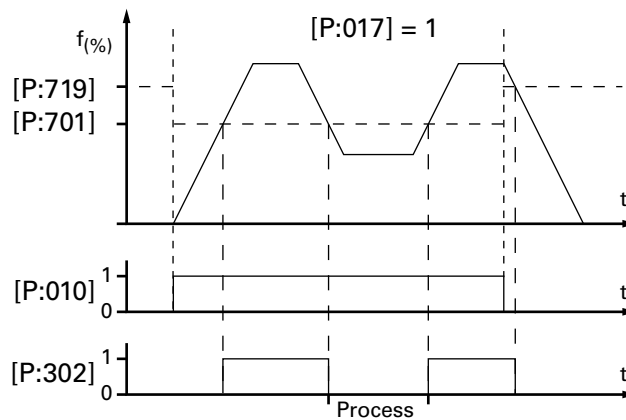

Fig. 7: Example for the configuration rotation speed switch points 1+2 active; [P:701] < [P:719]

### Rotation speed setting mode

The rotation speed setting mode reduces the rotation speed and hence the throughput of the turbopump. The pumping speed of the turbopump changes proportional to rotation speed. Standby mode is ineffective during rotation speed setting mode. The set rotation speed is adjusted by the set value in rotation speed setting mode **[P:707]**. The rotation speed switch point varies with the set rotation speed. Underrunning or overrunning the set value in rotation speed setting mode activates and deactivates the status signal **[P:306] SetSpdAtt** respectively.

- Adjust the parameter **[P:707]** to the desired value in %.
- Parameter **[P:026] = 1**
- Read the parameters **[P:308]/[P:397]**.

### Standby

Pfeiffer Vacuum recommends standby mode for the turbopump during process and production stops. When standby mode is active, the electronic drive unit reduces the rotation speed of the turbopump. The factory setting for the set value in standby mode is 66.7 % of the nominal rotation speed. Underrunning or overrunning the set speed in standby mode activates or deactivates the status signal **[P:306] SetSpdAtt**.

- Adjust the parameter **[P:717]** to the desired value in %.
- Parameter **[P:002] = 1**
- Read the parameters **[P:308]/[P:397]**.

### Rotation speed set value

The typical nominal rotation speed of a turbopump is factory-set in the electronic drive unit. If the electronic drive unit is replaced or a different pump type is used, the reference set value of the nominal rotation speed must be confirmed. This procedure is part of a redundant safety system for avoiding excess rotation speeds.

HiPace	Nominal rotation speed confirmation <b>[P:777]</b>
300	1000 Hz
400 / 700	820 Hz

- Adjust the parameter **[P:777]** according to the pump type.

Once the nominal rotation speed is attained, the pump will run idle unless additional gas loads are entered. Depending on process or application requirements, the nominal rotation speed can be reduced in rotation speed setting mode or standby mode.

### Operation mode backing pump

Operation of a connected backing pump via the electronic drive unit depends on the backing pump type.

Operation mode <b>[P:025]</b>	recommended backing pump
"0" continuous operation	all kinds of backing pumps
"1" Intermittend operation	diaphragm pumps only
"2" Delayed switching on	all kinds of backing pumps

- Adjust the parameter **[P:025]** to the desired value.

#### Continuous operation

With "pumping station on", the electronic drive unit sends a signal to the configured accessory connection to switch on the backing pump. This signal can also be used for controlling a fore-vacuum safety valve.

#### Intermittend operation (diaphragm pumps only)

Intermittend operation can extend the life expectancy of the membrane of a connected diaphragm pump. Either a diaphragm pump with built-in semiconductor relay or an interconnected relay box with semiconductor relay is required for intermittend operation. The backing pump is switched on and off in dependence of the turbopump's power consumption. A relation to the supplied fore-vacuum pressure is derived from the power consumption. The switching off and switching on thresh-

olds for the backing pump are adjustable. Fluctuations in the power consumption of idling turbopumps and type-dependent varying fore-vacuum pressures of the backing pumps require the switching thresholds to be set separately for the inter-mittend mode.

Pfeiffer Vacuum recommends the intermittend mode between 5 and 10 mbar. A pressure gauge and a dosing valve are required to set the switching thresholds.

- Switch on the vacuum system via the function "pumping station" and await the run-up.
- Generate a fore-vacuum pressure of 10 mbar by gas inlet via dosing valve.
- Read and note the parameter **[P:316]**.
- Adjust the switch on threshold backing pump via parameter **[P:711]** to the determined drive power for a fore-vacuum pressure of 10 mbar.
- Reduce the fore-vacuum pressure to 5 mbar.
- Read and note the parameter **[P:316]**.
- Adjust the switch off threshold backing pump via parameter **[P:710]** to the determined drive power for a fore-vacuum pressure of 5 mbar.

### Delayed switching on

Switching on the turbopump and the backing pump at the same time can result in unwanted gas flows. Depending on process or application requirements, the backing pump can be switched on with a delay. The switch-on delay depends on the rotation speed of the turbopump and is fixed in the electronic drive unit at 6 Hz.

The switch-on delay signal can also be used for switching a fore-vacuum safety valve.

## Switching on the pumping station

The function "pumping station" comprises turbopump operation with control of all connected accessories (e.g. backing pump).

- Switch on the supply voltage with switch S1 on the power supply.
- Parameter **[P:023]** = 1
- Parameter **[P:010]** = 1

Ongoing (and removed) error messages are reset. After a successfully completed self-test, the electronic drive unit sets the turbopump motor and all connected accessories into operation depending on their configuration.

When the pumping station is activated, the turbopump can be switched off and on via the function **[P:023]**.

## Operation with accessories

Depending on the configuration, various accessories can be connected to the turbopump and controlled via parameter of the electronic drive unit.

### Heating

- Switch on or off the heating via parameter **[P:001]**.

The activation of a connected casing heating depends on rotation speed switch point 1 (factory setting:  $80\% \times f_{\text{Nominal}}$ ).

### Fan

Two options in the connection configuration enable continuous or temperature controlled operation of a connected air cooling unit (see p. 17, chap. 7.3). Threshold values are type-specific and are anchored in the electronic drive unit.

### Sealing gas valve

- Switch on or off a sealing gas valve which is connected to a pre-configured output via parameter **[P:050]**.

## Vent modes

The turbopump can be vented only after the function "pumping station" has been switched off. Signals are sent to configured outputs with a fixed delay of 6 s. There are three options for operation with a venting valve connected.

- Enable venting via parameter [P:012].
- Select the venting mode via parameter [P:030].

### Delayed venting

Start and venting time after "pumping station off" are configurable and depend on the rotation speed of the turbopump.

- Parameter [P:030] = 0
- Adjust the venting rotation speed in % of the nominal rotation speed via parameter [P:720].
- Adjust the venting time in s via parameter [P:721].

If the venting rotation speed is underrun, the venting valve will open for the set venting time. In the event of a power failure, venting will occur if the set venting rotation speed is underrun. In this case, the venting period depends on the residual energy delivered by the moving rotor. When power is restored, the venting process is interrupted.

### No venting

No venting is performed during this operation mode.

- Parameter [P:030] = 1

### Direct venting

Start and venting time are not configurable. Venting starts with a delay of 6 s after "pumping station off". When the function "pumping station" is switched on renewed, the venting valve closes automatically. In the event of a power failure, venting will occur if an anchored type-specific rotation speed is underrun. When power is restored, the venting process is interrupted.

- Parameter [P:030] = 2

## Monitoring the thermal load

If threshold values are overrun, output signals from temperature sensors allow the pump to be brought to a safe condition. Depending on pump type, temperature threshold values for warnings and error messages are saved fixed in the electronic drive unit. For information purposes, various status queries are prepared in the parameter set.

## 8 Pfeiffer Vacuum Protocol for "RS485"

### 8.1 Telegram frame

The telegram frame of the Pfeiffer Vacuum protocol contains only ASCII code characters [32; 127], the exception being the end character of the message  $C_R$ . Basically, a master  $\square$  (e.g. a PC) sends a telegram, which is answered by a slave  $\circ$  (e.g. electronic drive unit).

a2	a1	a0	*	0	n2	n1	n0	l1	l0	dn	...	d0	c2	c1	c0	$C_R$
a2 - a0		Unit address for slave $\circ$ - Individual address of the unit ["001";"255"] - Group address "9xx" for all identical units (no response) - global address "000" for all units on the bus (no response)														
*		Action (see p. 25, chap. 8.2)														
n2 - n0		Pfeiffer Vacuum parameter numbers														
l1 - l0		Data length dn ... d0														
dn - d0		Data in data type concerned (see p. 26, chap. 8.3)														
c2 - c0		Checksum (sum of ASCII values of cells a2 to d0) modulo 256														
$C_R$		carriage return (ASCII 13)														

### 8.2 Telegrams

Data request  $\square \Rightarrow \circ ?$

a2	a1	a0	0	0	n2	n1	n0	0	2	=	?	c2	c1	c0	$C_R$
----	----	----	---	---	----	----	----	---	---	---	---	----	----	----	-------

Control command  $\square \Rightarrow \circ !$

a2	a1	a0	1	0	n2	n1	n0	l1	l0	dn	...	d0	c2	c1	c0	$C_R$
----	----	----	---	---	----	----	----	----	----	----	-----	----	----	----	----	-------

Data response / control command understood  $\circ \Rightarrow \square \checkmark$

a2	a1	a0	1	0	n2	n1	n0	l1	l0	dn	...	d0	c2	c1	c0	$C_R$
----	----	----	---	---	----	----	----	----	----	----	-----	----	----	----	----	-------

Error message  $\circ \Rightarrow \square \times$

a2	a1	a0	1	0	n2	n1	n0	0	6	N	O	_	D	E	F	c2	c1	c0	$C_R$
										-	R	A	N	G	E				
										-	L	O	G	I	C				

"NO_DEF"	The parameter n2 - n0 does not exist
"_RANGE"	Data dn - d0 are outside the permitted range
"_LOGIC"	Logic access violation

#### Example 1

Data request

Actual rotation speed (parameter [P:309], device address slave: "123")

$\square \Rightarrow \circ ?$	1	2	3	0	0	3	0	9	0	2	=	?	1	1	2	$C_R$
ASCII	49	50	51	48	48	51	48	57	48	50	61	63	49	49	50	13

Data request: 633 Hz

Actual rotation speed (parameter [P:309], device address slave: "123")

$\circ \Rightarrow \square \checkmark$	1	2	3	1	0	3	0	9	0	6	0	0	6	3	3	0	3	7	$C_R$
ASCII	49	50	51	49	48	51	48	57	48	54	48	48	54	51	51	48	51	55	13

#### Example 2

Control command

Switch on pumping station (parameter [P:010], device address slave: "042")

☐⇒○!	0	4	2	1	0	0	1	0	0	6	1	1	1	1	1	1	0	2	0	C <sub>R</sub>
ASCII	48	52	50	49	48	48	49	48	48	54	49	49	49	49	49	49	48	50	48	13

**Control command understood**

Switch on pumping station (parameter [P:010], device address slave: "042")

☐⇒○!	0	4	2	1	0	0	1	0	0	6	1	1	1	1	1	1	0	2	0	C <sub>R</sub>
ASCII	48	52	50	49	48	48	49	48	48	54	49	49	49	49	49	49	48	50	48	13

### 8.3 Applied data types

Data type	Description	Size I1 - I0	Example
0	False / true	06	000000 / 111111
1	Positive integer number	06	000000 to 999999
2	Positive fixed comma number	06	001571 equal to 15,71
4	Symbol chain	06	TC_400
7	Positive integer number	03	000 to 999
11	Symbol chain	16	BrezelBier&Wurst

## 9 Malfunctions

### 9.1 General



Turbopump and electronic drive unit malfunctions always result in a warning or error message. In both cases, the electronic drive unit outputs an error code. Operating messages are generally displayed via the LEDs on the electronic drive unit. If an error occurs, the turbopump and connected devices will be switched off. The selected venting mode will be triggered after the preset delay.



<b>WARNING</b>	
<b>Automatic start-up after error acknowledgement</b>	
The function "pumping station" of the electronic drive unit will remain active after a power failure or if errors occur that lead to shut down the pump or the system. The turbopump will automatically run-up once the error has been rectified and acknowledged.	
→ Switch off the function "pumping status" if necessary.	
→ Take suitable safety measures to prevent the high vacuum flange from meshing when the turbopump is running.	

## 9.2 Operating mode display via LED

LEDs in the front panel of the electronic drive unit show basic operating conditions of the turbopump. A differentiated malfunction and warning display is possible only for operation with DCU or HPU.

LED	Symbol	Steady OFF	Flashing (1/12 s active)	Blinking (1/2 s active)	Steady ON
Green		insufficient power supply	Pumping station "OFF" Rotation speed $\leq$ 1Hz	Pumping station "OFF" Rotation speed $>$ 1 Hz	Pumping station "ON"
Yellow		no warning			Warning
Red		no malfunction			Malfunction

## 9.3 Error codes

Error code	Problem	Possible cause	Remedy
Err001	Excess rotation speed		⇒ Contact Pfeiffer Vacuum Service ⇒ Reset at rotation speed $f = 0$ only
Err002	Overvoltage	– Wrong mains pack used	⇒ Check type of mains pack ⇒ Check mains pack voltage
Err006	Run-up time error	– Run-up time too short – Gas flow in the vacuum chamber caused by leakage or open valves – Rotation speed switchpoint is under-run after run-up time is expired	⇒ Adjust run-up time to process ⇒ Check the vacuum chamber for leaks or closed valves ⇒ Adjust rotation speed switch point
Err007	Operating fluid deficiency	– Operating fluid deficiency	⇒ Check operating fluid ⇒ Reset at rotation speed $f = 0$ only
Err008	Connection electronic drive unit - pump faulty	– Connection to the pump is faulty	⇒ Check the connection ⇒ Reset at rotation speed $f = 0$ only
Err010	Internal device fault		⇒ Contact Pfeiffer Vacuum Service ⇒ Reset at rotation speed $f = 0$ only
Err021	Electronic drive unit does not recognizes pump		⇒ Contact Pfeiffer Vacuum Service ⇒ Reset at rotation speed $f = 0$ only
Err043	Internal configuration fault		⇒ Contact Pfeiffer Vacuum Service
Err044	Excess temperature electronic	– Cooling deficient	⇒ Optimize cooling ⇒ Check the ambient conditions
Err045	Excess temperature motor	– Cooling deficient	⇒ Optimize cooling ⇒ Check the ambient conditions
Err046	Internal initialization fault		⇒ Contact Pfeiffer Vacuum Service
Err091	Internal device fault		⇒ Contact Pfeiffer Vacuum Service
Err092	Unknown connection panel		⇒ Contact Pfeiffer Vacuum Service
Err093	Temperature analysis motor faulty		⇒ Contact Pfeiffer Vacuum Service
Err094	Temperature analysis electronic faulty		⇒ Contact Pfeiffer Vacuum Service
Err098	Internal communication fault		⇒ Contact Pfeiffer Vacuum Service
Err107	Collective fault power stage		⇒ Contact Pfeiffer Vacuum Service ⇒ Reset at rotation speed $f = 0$ only
Err108	Rotation speed measurement faulty		⇒ Contact Pfeiffer Vacuum Service ⇒ Reset at rotation speed $f = 0$ only
Err109	Firmware not confirmed		⇒ Contact Pfeiffer Vacuum Service
Err110	Operating fluid analysis faulty		⇒ Contact Pfeiffer Vacuum Service ⇒ Reset at rotation speed $f = 0$ only
Err111	Communication fault operating fluid pump		⇒ Contact Pfeiffer Vacuum Service ⇒ Reset at rotation speed $f = 0$ only
Err112	Collective fault operating fluid fault		⇒ Contact Pfeiffer Vacuum Service ⇒ Reset at rotation speed $f = 0$ only
Err113	Rotor temperature invalid	– Measurement not calibrated	⇒ Contact Pfeiffer Vacuum Service
Err114	Temperature analysis power stage faulty		⇒ Contact Pfeiffer Vacuum Service

Error code	Problem	Possible cause	Remedy
Err117	Excess temperature pump bottom part	- Cooling deficient	⇒ Optimize cooling ⇒ Check the ambient conditions
Err118	Excess temperature power stage	- Cooling deficient	⇒ Optimize cooling ⇒ Check the ambient conditions
Err119	Excess temperature bearing	- Cooling deficient	⇒ Optimize cooling ⇒ Check the ambient conditions
Err143	Excess temperature operating fluid pump	- Cooling deficient	⇒ Optimize cooling ⇒ Check the ambient conditions ⇒ Reset at rotation speed $f = 0$ only
Err777	Nominal rotation speed not confirmed	- Nominal rotation speed not confirmed after replacement of the electronic drive unit	⇒ Confirm the nominal rotation speed via <b>[P:777]</b> ⇒ Reset at rotation speed $f = 0$ only
Wrn007	Low voltage / mains power failure	- Mains failure	⇒ Check mains supply
Wrn018	Remote priority conflict	- Pumping station is switched on via <b>[P:010]</b> , whereas the E74-input "start/stop" is off (opened)	⇒ Switch on the pumping station via E74 ⇒ Switch off <b>[P:010]</b>
Wrn045	High temperature motor	- Cooling deficient	⇒ Optimize cooling ⇒ Check the ambient conditions
Wrn076	High temperature electronic	- Cooling deficient	⇒ Optimize cooling ⇒ Check the ambient conditions
Wrn097	Pump information invalid	- Pump data faulty	⇒ Reset for default values
Wrn098	Pump information incomplete	- Connection to the pump is faulty	⇒ Contact Pfeiffer Vacuum Service
Wrn113	Rotor temperature inaccurate	- Measurement not calibrated	⇒ Contact Pfeiffer Vacuum Service
Wrn115	Temperature analysis pump bottom part faulty		⇒ Contact Pfeiffer Vacuum Service
Wrn116	Temperature analysis bearing faulty		⇒ Contact Pfeiffer Vacuum Service
Wrn117	High temperature pump bottom part	- Cooling deficient	⇒ Optimize cooling ⇒ Check the ambient conditions
Wrn118	High temperature power stage	- Cooling deficient	⇒ Optimize cooling ⇒ Check the ambient conditions
Wrn119	High temperature bearing	- Cooling deficient	⇒ Optimize cooling ⇒ Check the ambient conditions
Wrn143	High temperature operating fluid pump	- Cooling deficient	⇒ Optimize cooling ⇒ Check the ambient conditions
Wrn168	High deceleration	- Rate of pressure rise too high; Venting rate to high	⇒ Check and optimize the venting rate (pump specific)

## 10 Accessories

An overview about original Pfeiffer Vacuum accessories for the designated device can be found in the operating instructions of the respective vacuum pump.



# Declaration of conformity

pursuant to the following EU directives:

- **Electromagnetic Compatibility 2004/108/EC**
- **Low Voltage 2006/95/EEC**

We hereby certify, that the product specified below is in accordance with the provision of EU Electromagnetic Compatibility Directive **2004/108/EEC** and EU Low Voltage Directive **2006/95/EEC**.

**TC 400**

Guidelines, harmonised standards and national standards in languages and specifications which have been applied:

EN 61000-3-2 : 2006  
EN 61000-3-3 : 1995  
EN 61010-1 : 2001  
EN 61326-1 : 2006  
EN 62061 : 2005  
Semi F47-0200

Signatures:

Pfeiffer Vacuum GmbH  
Berliner Straße 43  
35614 Asslar  
Germany

---

(M. Bender)  
Managing Director

(Dr. M. Wiemer)  
Managing Director

CE/2009

**Vacuum is nothing, but everything to us!**



**Turbopumps**



**Rotary vane pumps**



**Roots pumps**



**Dry compressing pumps**



**Leak detectors**



**Valves**



**Components and feedthroughs**



**Vacuum measurement**



**Gas analysis**



**System engineering**



**Service**

**PFEIFFER**  **VACUUM**

Pfeiffer Vacuum Technology AG · Headquarters/Germany

Tel. +49-(0) 64 41-8 02-0 · Fax +49-(0) 64 41-8 02-2 02 · [info@pfeiffer-vacuum.de](mailto:info@pfeiffer-vacuum.de) · [www.pfeiffer-vacuum.net](http://www.pfeiffer-vacuum.net)